

# TRANSPALETA ELÉCTRICA

2.000 Kg. - 3 HORAS

Modelo de transpaleta perteneciente a la gama eléctrica con una capacidad de 2.000 Kg. y autonomía de 3 horas aproximadamente. Combina todos los factores de rendimiento necesarios: motor con potencia, dirección precisa y dimensiones óptimas. Es la opción perfecta para trabajar en espacios reducidos que requieran una mayor capacidad de carga para coger palés más pesados. Se utiliza principalmente en supermercados, camiones, almacenes...

## DATOS TÉCNICOS

Characteristics	Power unit		Electric
	Operation		Pedestrian
	Rated traction weight	Q (t)	2.0
	Load centre	c (mm)	600
	Axle centre to fork face	x (mm)	944
	Wheel base	y (mm)	1243
Weights	Service weight with battery	kg	146
Wheels, Tyres	Wheels type		PU
	Driving wheel size	Φ×w(mm)	Φ210×70
	Bearing wheel size	Φ×w(mm)	Φ80×60
	Wheels, number front/rear (x = driven)		1x/4
	Track width	b <sub>11</sub> (mm)	400/535
Dimensions	Lift	h <sub>3</sub> (mm)	200
	Overall height(With handle)	h <sub>14</sub> (mm)	740/1160
	lowered height	h <sub>13</sub> (mm)	85
	Overall length	l <sub>1</sub> (mm)	1603
	Length to fork face	l <sub>2</sub> (mm)	453
	Overall width	b <sub>1</sub> / b <sub>2</sub> (mm)	550/685
	Fork dimensions	s/e/l (mm)	50/150/1150
	Width of forks	b <sub>5</sub> (mm)	550/685
	Min.Ground clearance	m <sub>2</sub> (mm)	35
	Aisle width with pallet 1000 x 1200 across forks	A <sub>st</sub> (mm)	1804
	Aisle width with pallet 800 x 1200 along forks	A <sub>st</sub> (mm)	1854
	Min.Turning radius	W <sub>a</sub> (mm)	1398
	Performance	Travel speed,laden/unladen	(km/h)
Maximum climbing ability, with/without load		(%)	5/10
Service brake			Electromagnetic
Drive	Drive motor, 60 minute rating	(kW)	0.75
	Lift motor rating at S3 15%	(kW)	0.8
	Battery according to DIN 43531/35/36 A.B.C.no		no
	Battery voltage/rated capacity	(V/Ah)	48/20
	Battery weight (± 5%)	(kg)	10.2
Others	Type of drive control		DC
	Noise level at operator's ear	(dB(A))	≤70
	Steering type		Mechanical steering

**Los materiales y características están sujetos a modificaciones sin previo aviso.  
Datos valido salvo error.**

# FOTOS Y PLANOS

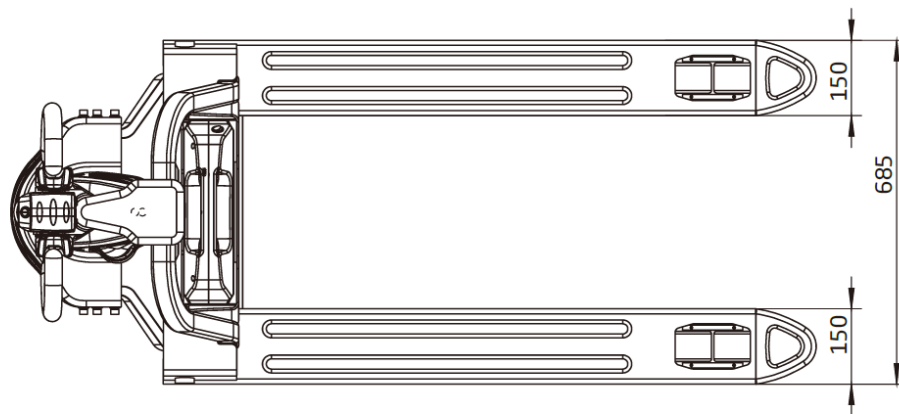
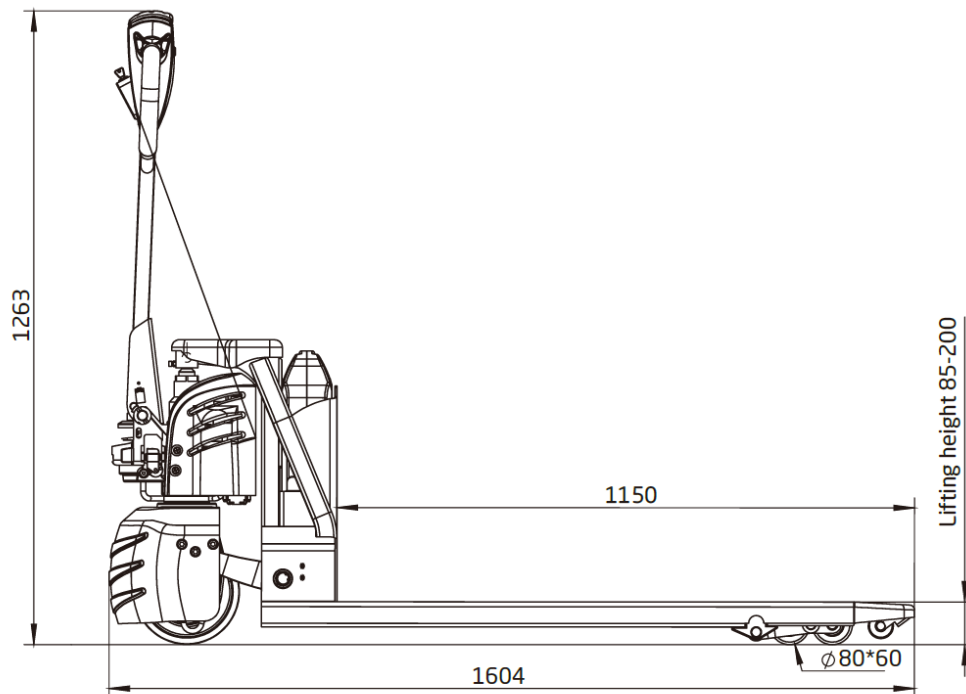

**NET QUINTOS, S.L.**  
91 854 14 14  
netquintos@netquintos.com  
www.netquintos.com