



CARRETILLA TODOTERRENO

4X2

Modelo todoterreno, compacto y resistente con un sistema de tracción en dos ruedas. De combustión interna, adopta el motor Diesel YANMAR, reconocido por su rendimiento superior y longevidad. El eje motriz está equipado con llantas de base ancha y de banda de rodadura profunda, frenos mejorados, cojinetes, diferencial con función de bloqueo automático, así como un renovado eje de dirección que proporciona la máxima tracción en condiciones y superficies complicadas. Por otro lado, el nuevo sistema de dirección hidráulica con detección de carga dinámica contribuye a mejorar la eficiencia energética. Asimismo, el nuevo sistema de iluminación LED reduce el consumo de energía, mejora significativamente el rendimiento de la iluminación y prolonga el tiempo de trabajo. Además, es un modelo de gran comodidad para el operario y de fácil mantenimiento.

DATOS TÉCNICOS

Distinguishing mark	Drive: electric (battery or mains), diesel, petrol, fuel gas		Diesel	Diesel	Diesel
	Operator type: hand, pedestrian, standing, seated, order-picker		Seated	Seated	Seated
	Rated capacity/rated load	Q (kg)	2500	3000	3500
	Load centre distance	c (mm)	500	500	500
	Load distance, centre of drive axle to fork	x (mm)	585	600	600
Weight	Wheelbase	y (mm)	1880	1880	1880
	Service Weight	kg	4670	5120	5380
	Axle loading, laden front/rear	kg	6050/1120	7080/1040	7800/1080
Tyres, chassis	Axle loading, unladen front/rear	kg	2010/2660	2300/2820	2280/3100
	Tyres: solid rubber, superelastic, pneumatic, polyurethane		Pneumatic	Pneumatic	Pneumatic
	Tyre size, front		12-16.5-14PR	14-17.5-14PR	14-17.5-14PR
	Tyre size, rear		27×10-12-12PR	27×10-12-12PR	27×10-12-12PR
	Wheels, number front / rear (x = driven wheels)		2x/2	2x/2	2x/2
	Tread, front	b10 (mm)	1250	1250	1250
Dimensions	Tread, rear	b11 (mm)	1200	1200	1200
	Tilt of mast/fork carriage forward/backward	$\alpha/\beta(^{\circ})$	10/12	10/12	10/12
	Height, mast lowered	h1 (mm)	2215	2350	2350
	Free lift	h2 (mm)	140	145	145
	Lift	h3 (mm)	3000	3000	3000
	Height, mast extended	h4 (mm)	4122	4142	4142
	Height of overhead guard (cabin)	h6 (mm)	2390	2420	2420
	Overall length	l1 (mm)	4205	4220	4220
	Length to face of forks	l2 (mm)	2985	3000	3000
	Overall width	b1 (mm)	1557	1599	1599
	Fork dimensions	s/e/l (mm)	40×122×1220	50×122×1220	50×122×1220
	Fork carriage DIN 15 173 --- ISO 2328, class/type A,B		B	B	B
	Fork-carriage width	b3 (mm)	1150	1150	1150
	Distance between fork-arms	b5 (mm)	290-1150	290-1150	290-1150
	Ground clearance, laden, below mast	m1 (mm)	240	270	270
	Ground clearance, centre of wheelbase	m2 (mm)	270	300	300
	Aisle width	Ast (mm)	4885	4900	4900
Turning radius	Wa (mm)	2900	2900	2900	
Performance data	Travel speed, laden/unladen	km/h	24/26	26/28	26/28
	Lift speed, laden/unladen	m/s	0.620/0.640	0.490/0.510	0.430/0.510
	Lowering speed, laden/unladen	m/s	0.500/0.440	0.500/0.450	0.500/0.450
	Drawbar pull, laden	N	21000	22000	23000
	Gradeability, laden	%	27	22	22
	Service brake		Hydraulic	Hydraulic	Hydraulic
	Parking brake		Mechanical	Mechanical	Mechanical
Electric engine	Engine manufacturer/type		YANMAR 4TNE98	YANMAR 4TNE98	YANMAR 4TNE98
	Engine power according to DIN ISO 1585	kw/r/min	42.1/2300	42.1/2300	42.1/2300
	Rated speed	N·m/r/min	196/1700	196/1700	196/1700
	Number of cylinders/displacement	(-)/(cm ³)	4/3319	4/3319	4/3319
	Battery voltage/nominal capacity	V/Ah	12/90	12/90	12/90
Addition data	Hydraulic Tank - capacity (drain & refill)	liter	65	65	65
	Fuel tank capacity	liter	65	65	65

2.5-3.5t Mast:(pneumatic)

Type	Max. fork height	Overall height						Free lift				Front Overhang		Tilt range	
		Lowered (mm)		Extended				Without backrest (mm)		With backrest (mm)		(mm)		FWD	BWD
				Without backrest (mm)		With backrest (mm)									
Wide view full free triplex mast	mm	2.5t	3/3.5t	2.5t	3/3.5t	2.5t	3/3.5t	2.5t	3/3.5t	2.5t	3/3.5t	2.5t	3/3.5t	(°)	(°)
	4500	2265	2450	5360	5525	5622	5769	1405	1425	1143	1181	603	618	10	12
	4700	2365	2550	5560	5725	5822	5969	1505	1525	1243	1281	603	618	10	12
	5000	2515	2700	5860	6025	6122	6269	1655	1675	1393	1431	603	618	6	6
	5500	2715	2900	6360	6525	6622	6769	1855	1875	1593	1631	603	618	6	6
6000	2965	3150	6860	7025	7122	7269	2105	2125	1843	1881	603	618	6	6	

Los materiales y características están sujetos a modificaciones sin previo aviso. Datos válidos salvo error.

FOTOS



PLANOS

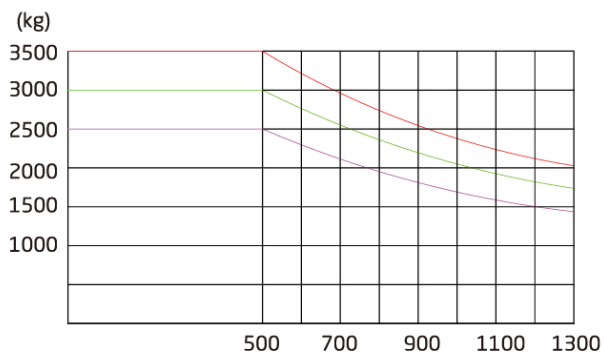
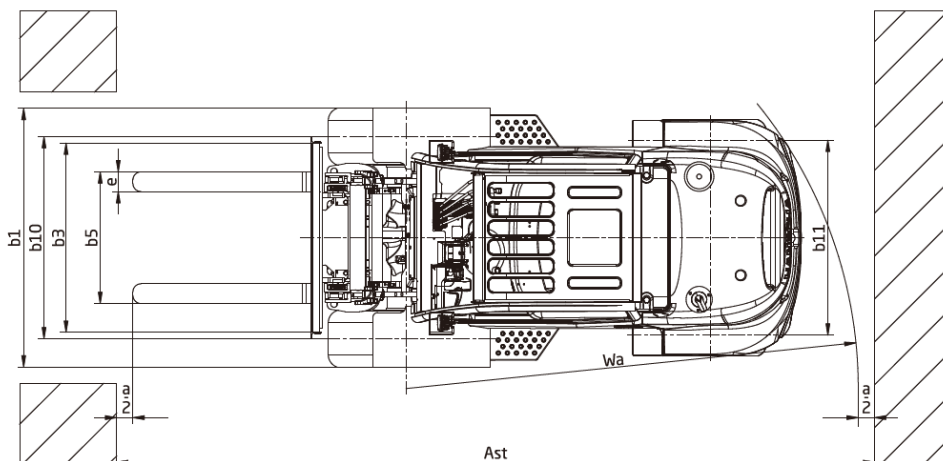
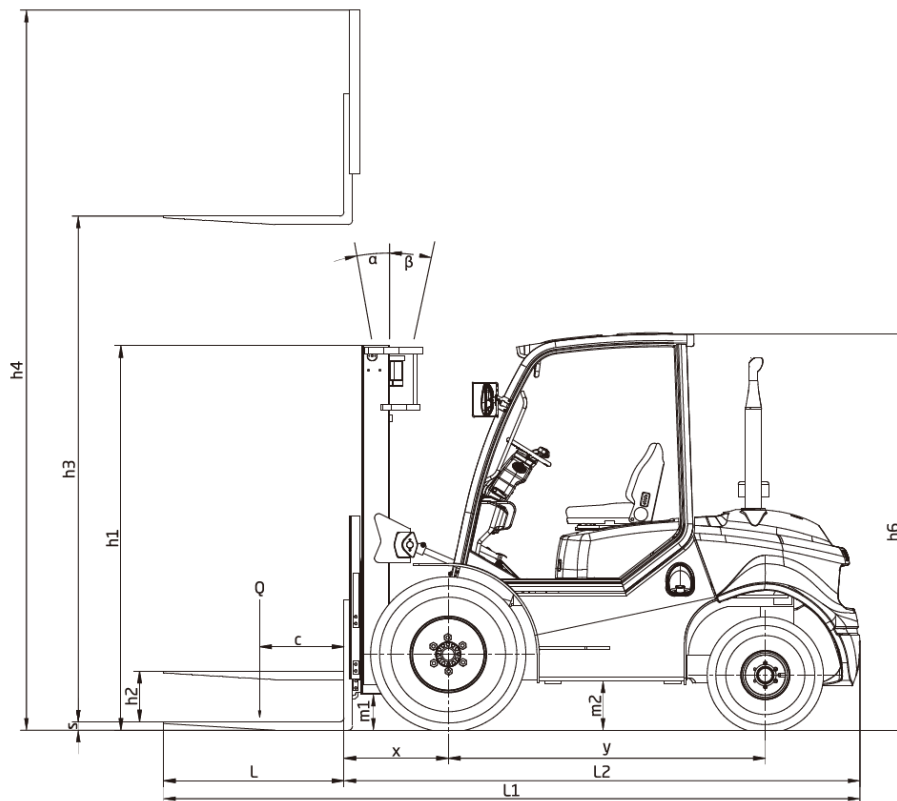

NET QUINTOS, S.L

91 854 14 14

netquintos@netquintos.com

www.netquintos.com