

MESA ELÉCTRICA

STANDARD

Plataforma elevadora con capacidad de carga de 1.000 Kg y 4.000 Kg. Eleva de manera eléctrica a alturas de entre 990 Mm y 1.400 Mm. Esta herramienta de trabajo está diseñada para alcanzar alturas de trabajo cómodas para que el operario pueda acceder a la carga de manera sencilla. Sus movimientos son suaves y automatizados. Tiene una estructura de acero rectangular para asegurar la estabilidad y resistencia de la mesa. Además, no requiere de mucho mantenimiento y tiene una larga vida útil.

DATOS TÉCNICOS

Modelo	Capacidad kg	Elevación mínima mm	Elevación Máxima mm	Dimensiones plataforma mm	Dimensiones de la base mm	Tiempo elevación mm	Motor	Peso kg
1001	1000	205	990	820X1300	640X1240	20-25	380V/50HZ ,AC1.1kw	160
1002	1000	205	990	1000X1600	640X1240	20-25		186
1003	1000	240	1300	850X1700	640X1580	30-35		200
1004	1000	240	1300	1000X1700	640X1580	30-35		210
1005	1000	240	1300	850X2000	640X1580	30-35		212
1006	1000	240	1300	1000X2000	640X1580	30-35		223
2001	2000	230	1000	850X1300	785X1220	20-25	380V/50HZ,AC2.2 kw	235
2002	2000	230	1000	1000X1600	785X1220	20-25		268
2003	2000	250	1300	850X1700	785X1600	25-35	380V/50HZ,AC1.5 KW	289
2004	2000	250	1300	1000X1700	785X1600	25-35		300
2005	2000	250	1300	850X2000	785X1600	25-35		300
2006	2000	250	1300	1000X2000	785X1600	25-35		315
4001	4000	240	1050	1200X1700	900X1600	30-40	380V/50HZ,AC2.2 kw	375
4002	4000	240	1050	1200X2000	900X1600	30-40		405
4003	4000	300	1400	1000X2000	900X2000	45-50		470
4004	4000	300	1400	1200X2000	900X2000	45-50		490
4005	4000	300	1400	1000X2200	900X2000	45-50		480
4006	4000	300	1400	1200X2200	900X2000	45-50		505

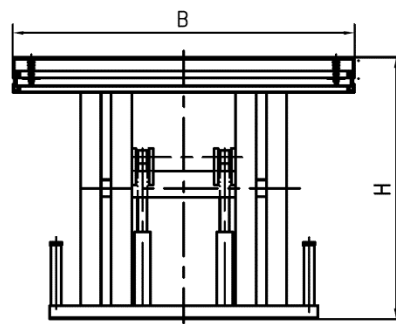
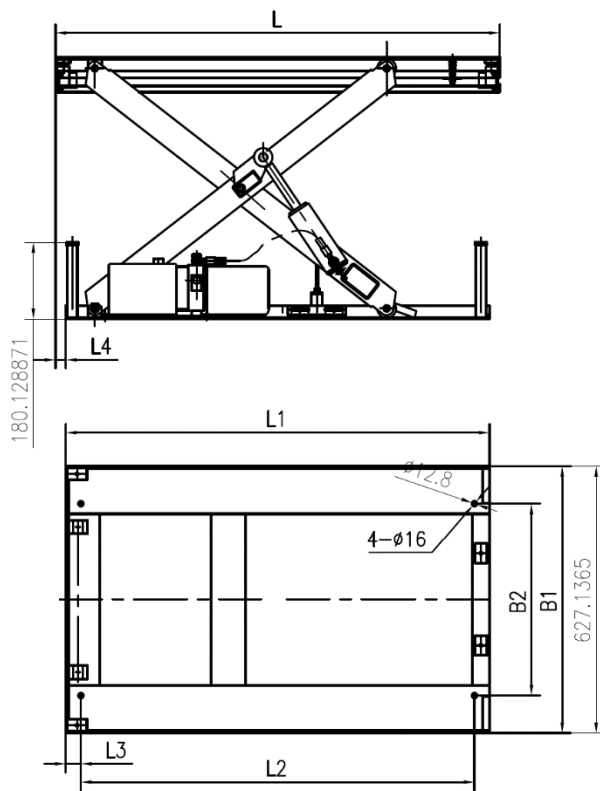

	L	B	L1	B1	L2	B2	L3	L4	H
1001	1300	820	1266	680	1206	480	30	30	205~990
1002	1600	1000	1266	680	1206	480	30	85	205~990
1003	1700	850	1600	680	1540	480	30	85	240~1300
1004	1700	1000	1600	680	1540	480	30	85	240~1300
1005	2000	850	1600	680	1540	480	30	215	240~1300
1006	2000	1000	1600	680	1540	480	30	215	240~1300
2001	1300	850	1255	785	1195	545	30	37	230~1000
2002	1600	1000	1255	785	1195	545	30	137	230~1000
2003	1700	850	1630	785	1570	545	30	47	250~1300
2004	1700	1000	1630	785	1570	545	30	47	250~1300
2005	2000	850	1630	785	1570	545	30	213	250~1300
2006	2000	1000	1630	785	1570	545	30	213	250~1300
4001	1700	1200	1600	930	1500	630	50	50	240~1050
4002	2000	1200	1600	930	1500	630	50	180	240~1050
4003	2000	1000	1980	930	1900	630	40	10	300~1400
4004	2000	1200	1980	930	1900	630	40	10	300~1400
4005	2200	1000	1980	930	1900	630	40	90	300~1400
4006	2200	1200	1980	930	1900	630	40	90	300~1400

Los materiales y características están sujetos a modificaciones sin previo aviso. Datos válidos salvo error.

FOTOS



NET QUINTOS, S.L

91 854 14 14

netquintos@netquintos.com

www.netquintos.com