



APILADOR ELÉCTRICO CONTRAPESADO

Este modelo de apilador eléctrico contrapesado es la herramienta logística perfecta para aquellas ocasiones en las que los apiladores con brazos de apoyo no pueden trabajar con palets cerrados o bajos. Su diseño compacto permite que sea posible operar en espacios más limitados. El timón cuenta con un diseño alargado para garantizar que las operaciones se realicen con mayor facilidad.

CARACTERÍSTICAS

Distinguishing Mark			
Drive unit			electric
Operating type			standing
Rated capacity	Q	kg	800
Load center	C	mm	450
Tyres, Chassis			
Wheel material			PU
Tyre size, loading wheels		mm	Ø160x70
Tyre size, driving wheels		mm	Ø210x70
Weight			
Net Weight ④		kg	1230
Dimensions			
Lift height ①	H	mm	3000
Lowered height	H1	mm	65
Fork dimentions	H3/B1/L	mm	32/100/1070
Outside width of the forks	E	mm	680
Overall length	A	mm	2300
Overall width	B	mm	1065
Height, mast lowered ②	H4	mm	2040
Height, mast extended ③	H5	mm	3495
Turning radius	Wa	mm	1200
Performance			
Travel speed, landen/unladen		Km/h	3-5
Lifting speed, laden/unladen		m/s	0.1-0.15
Lowering speed, laden/unladen		m/s	0.11-0.12
Max gradeability, laden/unladen		%	5-7
Service brake type			Electromagnetic
Electric engine			
Driving motor rating S2 60 min		Kw	0.75
Lifting motor rating S3 15%		Kw	1.5
Battery voltage/nominal capacity K20		V/Ah	12x2/120
Addition Data			
Type of drive control			DC Curtis 1212P
Steering type			Mechanical

Mast Option

Lift Height H(mm) ①	Lowered Mast Height H4(mm) ②	Extended Mast Height H5(mm) ③	Net Weight(kg) ④
1600	2090	2090	1155
2000	1540	2495	1180
2500	1790	2995	1205
3000	2040	3495	1230

Los materiales y características están sujetos a modificaciones sin previo aviso. Datos válidos salvo error.

FOTOS



PLANOS

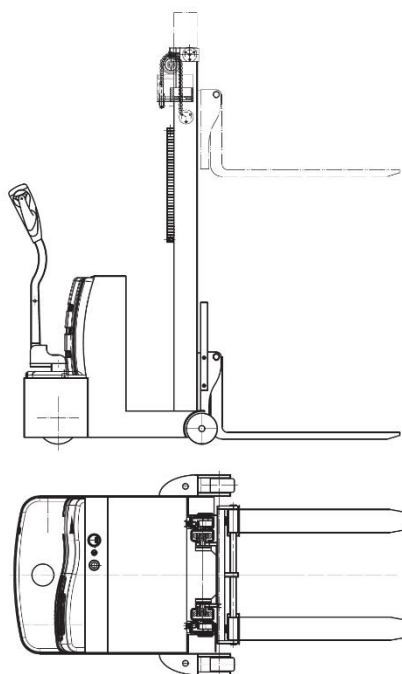

NET QUINTOS, S.L.

91 854 14 14

netquintos@netquintos.com

www.netquintos.com

